



PEDESTRIAN PALLET TRUCK T25 | T30

CAPACITY 2500 - 3000 KG | SERIES 1153

Safety

The T25/T30 benefits from a long tiller with a low mounting point ensuring a large safety clearance between operator and chassis. Creep speed and proportional speed functions, available as options, provide optimum safety during load transfer or when manoeuvring in tight corners.

Performance

This pallet truck is ideal for efficient handling of heavier loads. The compact and powerful 1.5 kW AC drive unit and the innovative castor wheels ensure the optimum mix of stability and traction in all situations. This all adds up to efficient and safe transfer of loads up to 3000 kg.

Comfort

All controls on the ergonomic tiller head can be easily operated by either hand. A Creep speed button offers utmost maneuverability in

confined areas. Generous storage compartments for work equipment such as shrink wrap eases the operator's tasks.

Reliability

The highly durable, robot welded construction of the pallet truck ensures consistent reliability and a long life in reference to demanding applications. Each heavy cast fork tip can support a load of 2000 kg without deformation. The arrow shaped fork tips also facilitate easy entry into every type of pallet and due to shrink wrapping, it ensures also fast, efficient, and safe load handling.

Service

A maintenance-free AC motor reduces service costs. Operating parameters can be individually adjusted to the operator's needs via the CAN-bus system. The service engineer has fast, easy access not only to truck data, via the CAN-bus system, but also to all main internal components.

TECHNICAL DATA

ACCORDING TO VDI 2198

			LINDE		
			T25	T30	
Characteristics	1.1	Manufacturer		LINDE	LINDE
	1.2	Model design		T25	T30
	1.3	Power unit		Battery	Battery
	1.4	Operation		Standing	Standing
	1.5	Load capacity / Load	Q (t)	2.5	3.0
	1.6	Load centre distance	c (mm)	600	600
	1.8	Axle centre to fork face	x (mm)	965	965
	1.9	Wheelbase	y (mm)	1453	1453
Weight	2.1	Service weight	(kg)	819	819
	2.2	Axle load with load, front / rear	(kg)	1428 / 1927	1572 / 2246
	2.3	Axle load without load, front / rear	(kg)	662 / 157	662 / 157
Wheels and types	3.1	Tyres rubber, SE, pneumatic, polyurethane		R + P / P	R + P / P
	3.2	Tyre size, front	(mm)	230 x 90	230 x 90
	3.3	Tyre size, rear	(mm)	85 x 85 (bogies 85 x 60)	85 x 85 (bogies 85 x 60)
	3.4	Auxiliary wheels (dimensions)	(mm)	2 x 125 x 60	2 x 125 x 60
	3.5	Wheels, number front / rear (x = driven)	(mm)	1x+2/2 (1x+1/4)	1x+2/2 (1x+1/4)
	3.6	Track width, front	b ₁₀ (mm)	502	502
	3.7	Track width, rear	b ₁₁ (mm)	380	380
Dimensions	4.4	Lift	h ₃ (mm)	125	125
	4.9	Height of tiller arm in operating position, min / max	h ₁₄ (mm)	855 / 1220	855 / 1220
	4.15	Height, lowered	h ₁₃ (mm)	86	86
	4.19	Overall length	l ₁ (mm)	1910	1910
	4.20	Length to fork face	l ₂ (mm)	756	756
	4.21	Overall width	b ₁ / b ₂ (mm)	720	720
	4.22	Fork dimensions DIN ISO 2331	s / e / l (mm)	55 x 165 x 1150	55 x 165 x 1150
	4.24	Width of fork carriage	b ₃ (mm)	710	710
	4.25	Fork spread	b ₅ (mm)	520 / 540 / 560 / 680	520 / 540 / 560 / 680
	4.32	Ground clearance, centre of wheelbase	m ₂ (mm)	30	30
	4.34.1	Aisle width for pallets 1000 x 1200 crossways	A ₃₁ (mm)	2500	2500
	4.34.2	Aisle width with pallet 800 x 1200 along forks	A ₃₁ (mm)	2635	2635
	4.35	Turning radius	W _a (mm)	1765 x 1835	1765 x 1835
Performance	5.1	Travel speed, with / without load	(km/h)	6.0 / 6.0	6.0 / 6.0
	5.2	Lifting speed, with / without load	(m/s)	0.028 / 0.036	0.026 / 0.036
	5.3	Initial lowering speed	(m/s)	0.066 / 0.072	0.065 / 0.072
	5.8	Maximum climbing ability, with / without load	(%)	12.0 / 20.0	10.0 / 20.0
	5.9	Acceleration time, with / without load	(s)	7.4 / 6.56	7.7 / 6.56
	5.10	Service brake		Electromagnetic	Electromagnetic
Drive	6.1	Drive motor rating S2 60 min	(kW)	1.5	1.5
	6.2	Lift motor rating at S3 15%	(kW)	1.5	2.2
	6.3	Battery according to DIN 43531/35/36 A, B, C, no		3PZs SL	3PZs SL
	6.4	Battery voltage / rated capacity (5h)	(V) / (Ah)	24 / 375	24 / 375
	6.5	Battery weight (± 5%)	(kg)	290	290
	6.6	Power consumption according to VDI cycle	(kWh/h)	0.483	0.572
8.1	Type of drive unit		LAC	LAC	
10.7	Sound pressure level LpAZ (at the driver's seat)	(dB(A))	60	60	

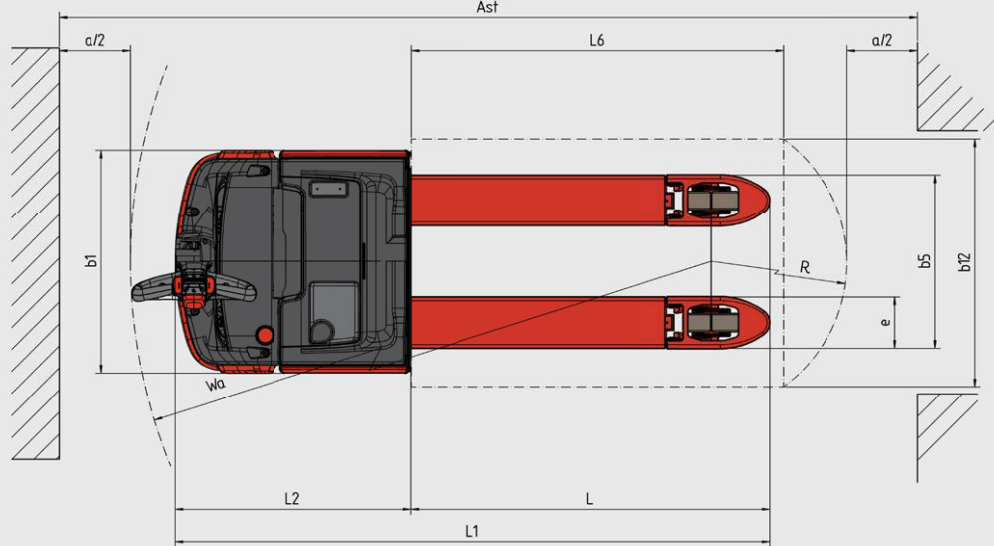
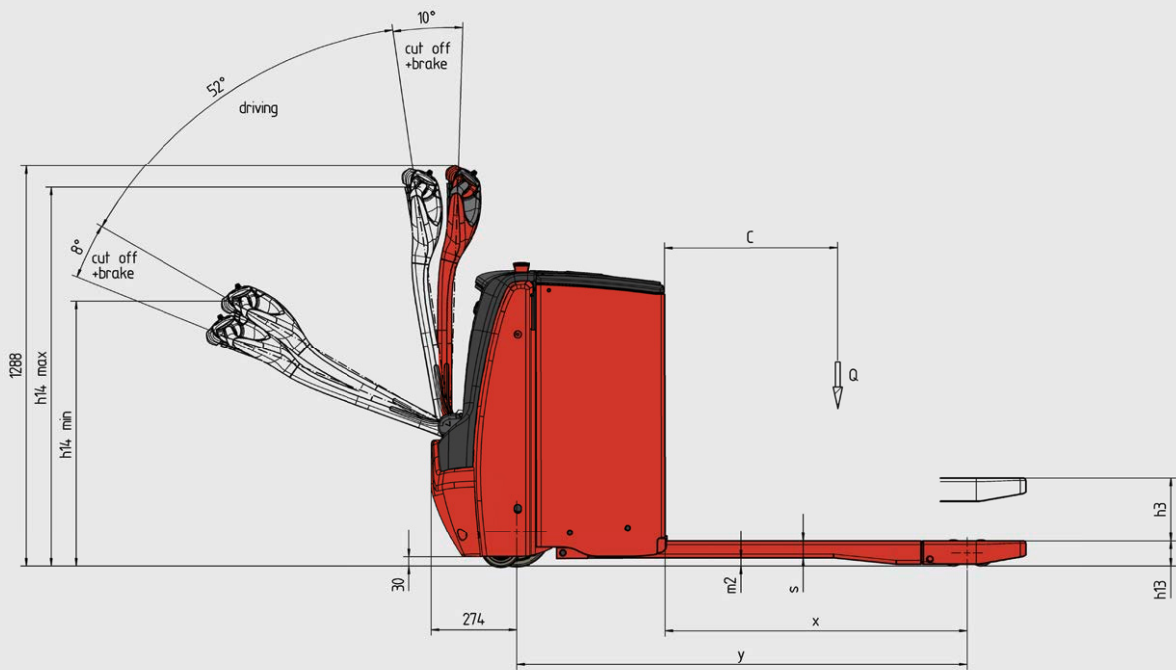

STANDARD EQUIPMENT / OPTIONAL EQUIPMENT

STANDARD EQUIPMENT

720 mm chassis width smaller than a pallet
Long tiller with a low mounting point
Power assisted steering with variable steering resistance
Automatic speed reduction when cornering
1.5 kW AC motor (maintenance free)
Vertical 3PzS battery compartment
Electromagnetic emergency brake acting proportionally to the load weight
Key switch or Log in PIN code (no extra)
Work station with storage compartments
CAN bus technology
Multifunction coloured display of the hour meter, maintenance indication, battery discharge indicator and internal fault code indication
Polyurethane drive wheel
Polyurethane single load wheels
Protection: -10° C

OPTIONAL EQUIPMENT

Drive wheels: cushion, cushion with tread, non-marking or wet grip
Load wheels: tandem polyurethane or single/tandem polyurethane greasable load wheels
Alternative fork dimensions
Load backrest 1800 mm/1200 mm
Low speed option when initial lift is lowered
Lift end stop sensor
Accessory support
Support data terminal incl. power supply cable 24V
Support clipboard DIN A4
Support for scanner
Built-in charger
Lateral 3PzS battery compartment
Lateral 4PzS battery compartment
Battery stand – fixed and mobile
Cold store protection: -35° C
Working lamp LED front
Blue spot
Other options available on request

Linde Connected Solutions:

ac: access control (PIN or RFID Dual),
an: usage analysis and dt: crash detection

Data transfer online

Data transfer WIFI

Bluetooth USB Stick

Li-ION technology:

3PzS compartment with 4.5 kWh - 9 kWh (205 Ah - 410 Ah)

Li-ION charger:

24 V-Charger v255: 4.5 kWh (full charging time 1h 30 min) -
9.0 kWh (2h 40 min)

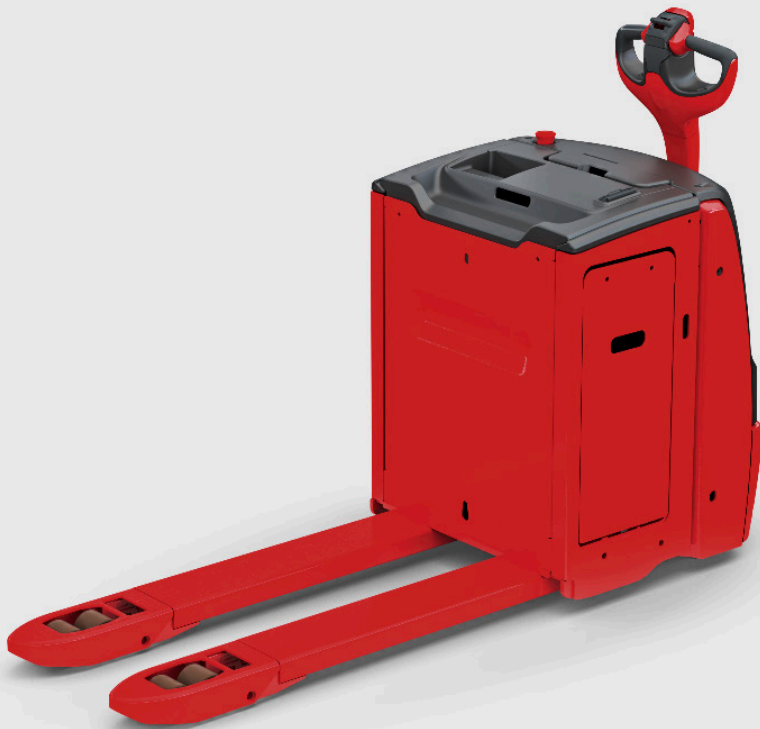

FEATURES

Steering system

- Proportional speed control varies truck speed automatically, in relation to the tiller angle for safe, comfortable, and productive operation
- End-of-stroke resistance on the tiller avoids accidental, abrupt braking
- Soft, fold-back tiller when returning into an upright position, avoiding the tiller from snapping on to the motor cover



Handling

- 720 mm chassis width narrower than a pallet
- Compact and robust chassis for easy handling in narrow spaces
- A Creep speed button ensures high maneuverability in confined areas when operating with the tiller in an upright position

Braking

- Highly efficient mechanical brake when the tiller is fully raised or lowered
- Automatic electric braking on releasing the butterfly control or reversing direction
- Truck slows down prior to stopping - remaining under complete control at all times
- No roll-back when starting on a slope

AC Motor

- Compact, efficient, and maintenance-free 1.5 kW AC motor
- Innovative castor wheel design offers maximum traction and stability for demanding applications, such as, loading/unloading

CAN-bus connectivity

- On-board diagnostics and CAN-bus interface
- Provides service technician with rapid access to all truck data for performance parameter settings, trouble shooting, and preventative maintenance



Workstation

- Multifunctional instrument display with an easy, ergonomic menu
- Truck access control by PIN code or ignition key
- Storage compartment for work gloves, writing utensils, etc.
- Preparation for data terminal
- Emergency isolator

Tiller and tiller head

- Long tiller with a low mounting point provides a large safety clearance between operator and chassis
- All controls are ergonomically integrated in the tiller head
- Easy-to-reach control buttons permits fingertip operation for utmost efficiency
- Wrap-around hand protection
- Twin grip steering control, operable with either hand for easy handling

Comprehensive energy solutions

- 24V batteries: capacities from 345 Ah (3PzS) to 500 Ah (4PzS)
- Li-ION batteries with 4.5 kWh (205 Ah) and 9.0 kWh (410 Ah)
- Optional built-in charger available
- Optional lateral change, including rollers inside the battery compartment and a lever to aid battery change

Subject to modification in the interest of progress. Illustrations and technical details could include options and not binding for actual constructions. All dimensions subject to usual tolerances.

Linde Material Handling

Linde Material Handling | 5 Distillers Place | Huntingwood NSW 2148
Phone 1300 135 463 | www.lindemh.com.au