



Pallet Trucks

T20 – T25 AP | SP

Capacity 2.0 – 2.5 t | Series 1156

Nimble all-rounder

- Compact pallet truck for efficient loading and unloading of delivery vehicles as well as transport and order picking
- Foldable operator's platform to use the vehicle as a manoeuvrable pedestrian or ride-on model (AP version)
- Unique platform concept with standing position at a 45° angle for better all-round vision and a comfortable body posture (SP version)
- Innovative Linde e-driver control concept for optimum truck handling in the 45° standing position (SP version)
- Fully suspended operator compartment reducing shocks and vibrations for smooth operation

TECHNICAL DATA (according to VDI 2198)

			Characteristics				
			Linde MH	Linde MH	Linde MH	Linde MH	
1.1	Manufacturer		Linde MH	Linde MH	Linde MH	Linde MH	
1.2	Model		T20 SP	T25 SP	T20 AP	T25 AP	
1.2a	Series		1156-00	1156-00	1156-00	1156-00	
1.3	Power unit		Battery	Battery	Battery	Battery	
1.4	Operation		Stand on	Stand on	Pedestrian/stand on	Pedestrian/stand on	
1.5	Load capacity/Load	Q (t)	2.0	2.5	2.0	2.5	
1.6	Load centre distance	c (mm)	600	1200	600	1200	
1.8	Axle centre to fork face	x (mm)	900/970 ^{1) 2)}	1762/1832 ^{1) 2)}	900/970 ^{1) 2)}	1762/1832 ^{1) 2)}	
1.9	Wheelbase	y (mm)	1346/1416 ^{1) 2) 3)}	2208/2278 ^{1) 2) 3)}	1346/1416 ^{1) 2) 3)}	2208/2278 ^{1) 2) 3)}	
Weights	2.1	Service weight	kg	870 ^{4) 5)}	-	870 ^{4) 5)}	-
	2.2	Axle load with load, front/rear	kg	1200/1670 ^{4) 5) 6)}	-	1200/1670 ^{4) 5) 6)}	-
	2.3	Axle load without load, front/rear	kg	720/150 ^{4) 5)}	-	720/150 ^{4) 5)}	-
Wheels /tyres	3.1	Tyres rubber, SE, pneumatic, polyurethane		Polyurethane	Polyurethane	Polyurethane	Polyurethane
	3.2	Tyre size, front		Ø 254 × 102	Ø 254 × 102	Ø 254 × 102	Ø 254 × 102
	3.3	Tyre size, rear		2x Ø85 × 80	2x Ø85 × 80	2x Ø85 × 80	2x Ø85 × 80
	3.4	Auxiliary wheels (dimensions)		2x Ø 125 × 60	2x Ø 125 × 60	2x Ø 125 × 60	2x Ø 125 × 60
	3.5	Wheels, number front/rear (x = driven)		1x + 2/2 (1x + 2/4) ⁷⁾	1x + 2/2 (1x + 2/4) ⁷⁾	1x + 2/2 (1x + 2/4) ⁷⁾	1x + 2/2 (1x + 2/4) ⁷⁾
	3.6	Track width, front	b10 (mm)	572 ¹⁾	572 ¹⁾	572 ¹⁾	572 ¹⁾
	3.7	Track width, rear	b11 (mm)	355/375/395/515 ¹⁾	355/375/395/515 ¹⁾	355/375/395/515 ¹⁾	355/375/395/515 ¹⁾
Dimensions	4.4	Lift	h3 (mm)	115 ⁸⁾	115 ⁸⁾	115 ⁸⁾	115 ⁸⁾
	4.9	Height of tiller arm in operating position, min/max	h14 (mm)	1207/1287 ¹⁾	1207/1287 ¹⁾	1149/1357 ¹⁾	1149/1357 ¹⁾
	4.15	Height, lowered	h13 (mm)	85 ⁹⁾	85 ⁹⁾	85 ⁹⁾	85 ⁹⁾
	4.19	Overall length	l1 (mm)	2276 ^{1) 3)}	3526 ^{1) 3)}	2249 ^{1) 3)}	3499 ^{1) 3)}
	4.20	Length to fork face	l2 (mm)	1126 ^{1) 3)}	1126 ^{1) 3)}	1099 ^{1) 3)}	1099 ^{1) 3)}
	4.21	Overall width	b1/b2 (mm)	790 ¹⁾	790 ¹⁾	790 ¹⁾	790 ¹⁾
	4.22	Fork dimensions DIN ISO 2331	s/e/l (mm)	55 × 165 × 1150	55 × 165 × 2400	55 × 165 × 1150	55 × 165 × 2400
	4.25	Fork spread	b5 (mm)	520/540/560/680 ¹⁾	520/540/560/680 ¹⁾	520/540/560/680 ¹⁾	520/540/560/680 ¹⁾
	4.32	Ground clearance, centre of wheelbase	m2 (mm)	30/160 ²⁾	30/160 ²⁾	30/160 ²⁾	30/160 ²⁾
	4.33	Load dimension b12 x l6	b12 × l6 (mm)	-	2x 800 × 1200	-	2x 800 × 1200
	4.34	Aisle width predetermined load dimensions	Ast (mm)	-	3841/3853 ^{2) 3)}	-	3814/3826 ^{2) 3)}
	4.34.1	Aisle width for pallets 1000 × 1200 crossways	Ast (mm)	2834/2897 ^{2) 3)}	3733/3781 ^{2) 3) 12)}	2807/2870 ^{2) 3)}	3706/3754 ^{2) 3) 12)}
	4.34.2	Aisle width with pallet 800 × 1200 along forks	Ast (mm)	2726/2757 ^{2) 3)}	-	2699/2730 ^{2) 3)}	-
4.35	Turning radius	Wa (mm)	2026/2096 ^{2) 3)}	2888/2958 ^{2) 3)}	1999/2069 ^{2) 3)}	2861/2931 ^{2) 3)}	
Performance	5.1	Travel speed, with/without load	km/h	11/14 ^{10) 11)}	11/14 ^{10) 11)}	11/14 ^{10) 11)}	11/14 ^{10) 11)}
	5.2	Lifting speed, with/without load	m/s	0.06/0.07 ¹⁰⁾	0.04/0.06 ¹⁰⁾	0.06/0.07 ¹⁰⁾	0.04/0.06 ¹⁰⁾
	5.3	Lowering speed, with/without load	m/s	0.06/0.08 ¹⁰⁾	0.07/0.06 ¹⁰⁾	0.06/0.08 ¹⁰⁾	0.07/0.06 ¹⁰⁾
	5.8	Maximum climbing ability, with/without load	%	17.0/20.0	15.0/20.0	17.0/20.0	15.0/20.0
	5.9	Acceleration time, with/without load	s	5.9/4.6	5.9/4.6	5.9/4.6	5.9/4.6
	5.10	Service brake		Electric/hydraulic	Electric/hydraulic	Electric/hydraulic	Electric/hydraulic
Drive	6.1	Drive motor rating S2 60 min	kW	3	3	3	3
	6.2	Lift motor rating at S3 15%	kW	1.2	2.2	1.2	2.2
	6.3	Battery according to DIN 43531/35/36 A,B,C,no		43 535 B/3PzS	43 535 B/3PzS	43 535 B/3PzS	43 535 B/3PzS
	6.4	Battery voltage/rated capacity (5 h)	(V)/(Ah) o. kWh	24/345/375	24/345/375	24/345/375	24/345/375
	6.5	Battery weight (±5%)	kg	287	287	287	287
	6.6	Energy consumption according to DIN EN 16796	kWh/h	-	-	-	-
	6.6.1	CO2 equivalent according to EN 16796	kg/h	-	-	-	-
	6.7	Turnover output according to VDI 2198	t/h	-	-	-	-
6.8	Turnover efficiency according to VDI 2198	t/kWh	-	-	-	-	
Others	8.1	Type of drive unit		KWPC 05	KWPC 05	KWPC 05	KWPC 05
	10.7	Sound pressure level LpAZ (at the operator's seat)	dB(A)	-	-	-	-

- 1) (±5 mm)
2) Load arms upraised/lowered
3) ±0 mm = 2 PzS vertical or 3 PzS side change;
+75 mm = 3 PzS vertical or 4 PzS side change;
+150 mm = 4 PzS vertical;
+ 25 mm = 5PzS vertical.
4) Figures with battery, see line 6.4/6.5
5) (± 10%)
6) Figures in parenthesis with initial lift
7) Figures in parenthesis with tandem load wheels
8) (0/-5 mm)
9) (-0/+5 mm)
10) (±5%)
11) With hydraulic castor wheel
12) 2 × pallets

T20 - T25 SP

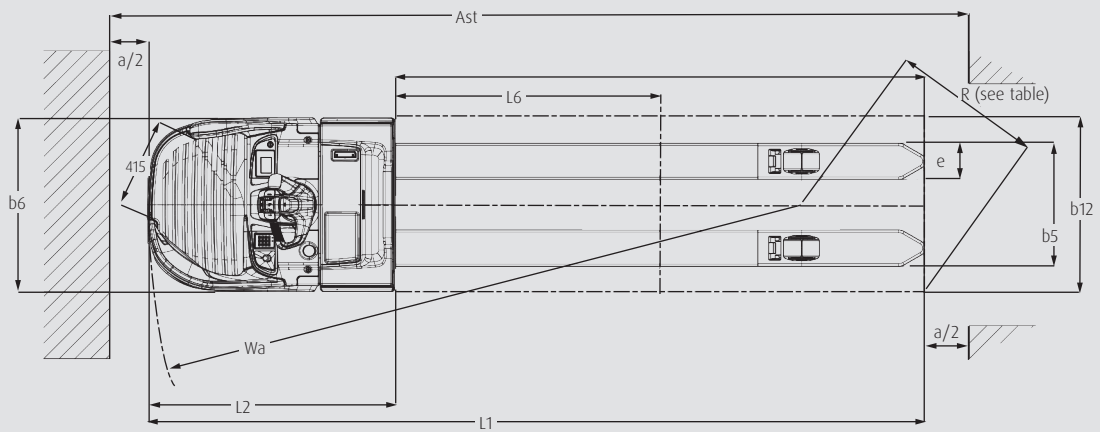
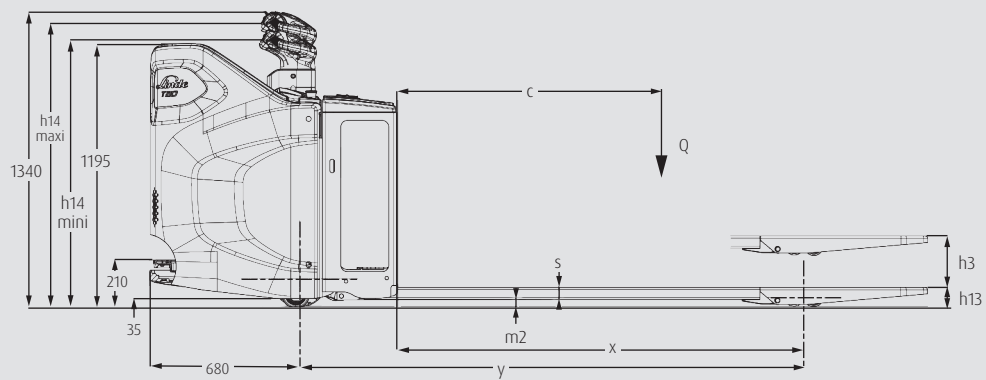

T20 - T25 AP

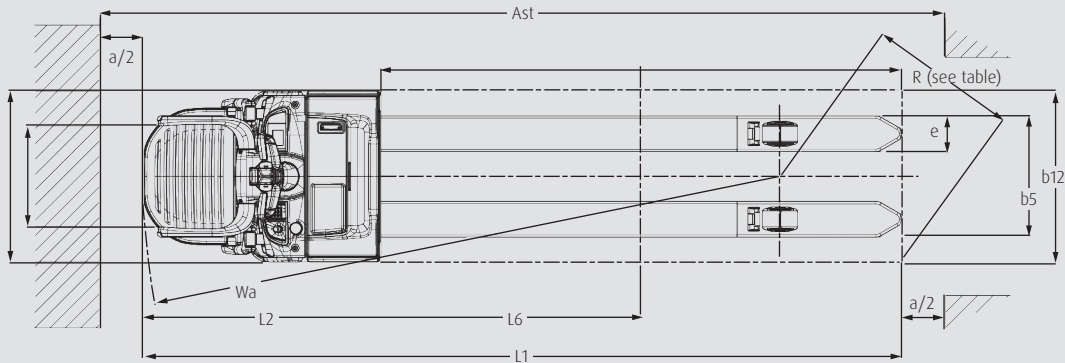
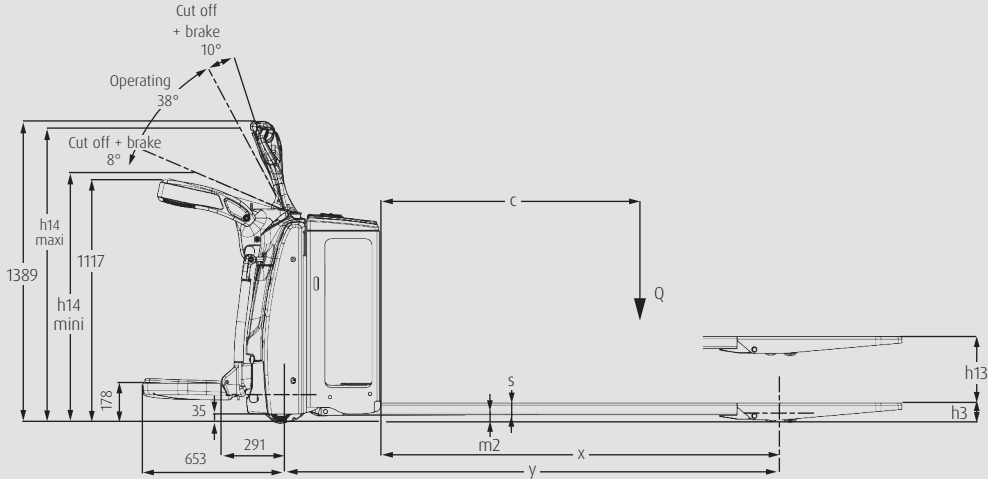

STANDARD AND OPTIONAL EQUIPMENT

Model/equipment		T20 AP	T25 AP	T20 SP	T25 SP
Safety	Automatic speed reduction when cornering	●	●	●	●
	Key switch	●	●	●	●
	Log in PIN code	○	○	○	○
	Folding sideguards and platform	●	●	—	—
	Unique, safe and intuitive 45° operating position	—	—	●	●
	BlueSpot® option - visual warning of truck presence integrated in the chassis contours	—	—	○	○
	BlueSpot® option - visual warning of truck presence mounted on accessory support	○	○	—	—
	Foot detection sensor - trucks slows down or stops if operator's foot is detected outside of the platform contours	—	—	○	○
Service	CAN bus technology	●	●	●	●
Digitalisation	Data transmission online	○	○	○	○
	Data transmission WiFi	○	○	○	○
	Linde connect:desk - local fleet management with different functional modules	○	○	○	○
	Linde connect:cloud - fleet management as a service (hosted version)	○	○	○	○
	Linde Pre-Op Check App - personalised daily check protocol for operational readiness	○	○	○	○
Operation/load handling	Creep speed - for operation with tiller in vertical position	○	○	—	—
	Linde Safety Guard speed reduction (zi ready)	○	○	○	○
	Low speed if initial lift lowered	○	○	○	○
	Maximum operating speed limitation (8, 10, 12, 14 km/h, depending on the model)	○	○	○	○
	Load backrest h=1200 mm or 1800 mm	○	○	○	○
Environment	Coldstore -35°C (in/out) - with metal grid or standard floor mat	○	○	○	○
Workplace	Fully suspended operator compartment - both feet platform and steering unit are suspended	●	●	●	●
	Padded leg rest and backrest	—	—	●	●
	Twin-grip handlebar	●	●	●	●
	Innovative Linde e-driver control perfectly suited for the 45° operation	—	—	○	○
	Height-adjustable steering unit	—	—	○	○
	Multifunction coloured display hour meter, maintenance indication, battery discharge indicator and internal fault code indication	○	○	○	○
	Accessory support	○	○	○	○
	Support for data terminal and power supply cable 24V	○	○	○	○
	Scanner support and clipboard	○	○	○	○
	Electrical socket USB 5V	○	○	○	○
Attachment /forks	Fork widths: 520 mm, 540 mm, 560 mm, 680 mm	○	○	○	○
	Fork lengths: 1000 mm, 1150 mm, 1600 mm, 2400 mm	○	○	○	○
Axles and tyres	Drive wheel heavy duty, polyurethane non-marking	●	●	●	●
	Drive wheel high grip, polyurethane non-marking	○	○	○	○
	Single load wheel, polyurethane (also available in greasable version)	●	●	●	●
	Tandem load wheel polyurethane (also available in greasable version)	○	○	○	○
	Castor wheels with spring cylinder	○	○	○	○
	Hydraulic castor wheels, electronically controlled	○	○	○	○
Drive and braking system	Power steering	●	●	●	●
	Maintenance-free AC motor	●	●	●	●
	Electromagnetic braking system (or electromechanic)	●	●	●	●
	Li-ION and lead-acid technology available with different battery capacities depending on the model	○	○	○	○
	Integrated charger for lead-acid and Li-ION batteries	○	○	○	○
	External chargers available	○	○	○	○
Lighting	Working lamp - with on/off switch for operation in dark environments	○	○	○	○

● Standard equipment

○ Optional equipment

— Not available

CHARACTERISTICS



Safe 45° stand-on fixed platform

Safety

- Automatic adjustment of operating speed when cornering to prevent risky manoeuvres
- Foot detection automatically brings the vehicle to a smooth stop when operator's feet leave the platform (SP version)
- Fold-up side bars to protect the operator from injury in the event of collision (AP version)
- Dead man's switch and traction control for the highest possible safety in every work



Ergonomic, height-adjustable tiller

Ergonomics

- Fully decoupled operator platform for effective protection against vibrations and shocks
- Electric power steering for effortless vehicle control, including automatic steering resistance adjustment
- Unique concept with 45° operating position for optimal all-round view without straining back and neck (SP version)
- Innovative steering concept Linde e-driver for optimum, single-handed control of the vehicle in the 45° position if required (SP version)
- Automatic and gradual adjustment of vehicle speed for precise manoeuvring in tight spaces



Li-ION technology available

Handling

- High top speed of 14 km/h without load for fast transport travel
- Powerful 3 kW three-phase motor for rapid acceleration and maximum vehicle performance on inclines
- Special starting system to prevent unintentional rolling backwards on steep ground (e.g. on loading ramps)
- Mechanically sprung or hydraulic castor wheels guarantee high operating stability on uneven ground
- New generation of Li-ION batteries for more efficient energy use and optimised charging management



Foldable platform with robust sideguards

Service

- Robust three-phase motor for long service intervals and low maintenance costs
- Solid construction with durable parts and sturdy chassis for maximum vehicle availability
- Effortless accessibility of all relevant components thanks to consistent design-to-service principle
- Innovative CAN bus architecture for easy access to all vehicle data via diagnostic connector

Presented by:

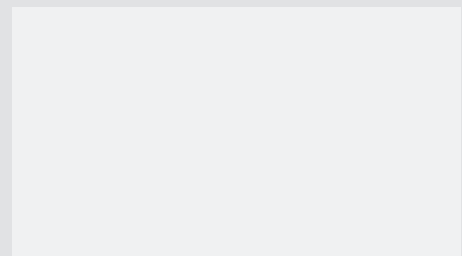

Linde Material Handling

Linde

Subject to modification in the interest of progress. Illustrations and technical details could include options and are not binding for actual constructions. All dimensions subject to usual tolerances.