



Electric Counterbalance Truck

X35-X50

Load capacity 3.5 – 5.0 t | Series 1254

ION

Performance

This robust electric forklift truck features a long wheelbase and high ground clearance, making it ideal for intensive outdoor operating conditions. Equipped with high-performance synchronous reluctance motors (SRM+) and water-cooled power modules, it ensures maximum performance under any load.

Comfort

The ergonomic steering wheel ensure an effortless operation. Double pedal control facilitates rapid reversing without the need to change foot positions. A wide seat selection is available for better ergonomics and comfort. The high and wide operator overhead guard affords a spacious working area.

Safety

The truck's intuitive operating controls, excellent visibility, and ergonomic design guarantee a high level of comfort and safety. These features ensure productive load handling.

Stability

Enhanced residual capacities enable lifting at maximum heights. Further enhancing safety and performance, the low center of gravity and high-mounted steering axle synergize to improve stability during cornering.

Reliability

The truck comes standard with a data transmission unit, enabling seamless integration into digital processes. Five additional models are available, each equipped with a comprehensive range of standard features. Additionally, a selection of optional equipment is available, allowing you to customise the truck to suit any application.

TECHNICAL DATA (according to VDI 2198)

Characteristics	1.1	Manufacturer (short name)		LINDE MH	LINDE MH	LINDE MH	LINDE MH
	1.2	Manufacturer's model designation		X35 / 600	X40 / 600	X45 / 600	X50 / 500
	1.2a	Series		1254-01	1254-01	1254-01	1254-01
	1.3	Drive		Battery	Battery	Battery	Battery
	1.4	Operation		Seated	Seated	Seated	Seated
	1.5	Load capacity	Q (t)	3.5	4.0	4.5	4.99
	1.6	Load centre distance	c (mm)	600	600	600	500
	1.8	Load spacing	x (mm)	525.2	535.2	535.2	535.2
	1.9	Wheel base	y (mm)	2120	2120	2120	2120
Weights	2.1	Empty weight	kg	6880 ¹⁾	6918 ¹⁾	7194 ¹⁾	7170 ¹⁾
	2.2	Axle load with load, front/rear	kg	8863/1517	9699/1219	10,460/1234	10,938/1222
	2.3	Axle load without load, front/rear	kg	3505/3375 ¹⁾	3557/3361 ¹⁾	3550/3644 ¹⁾	3511/3659 ¹⁾
Wheels/Tyres	3.1	Tyres solid rubber, SE, pneumatic, polyurethane		SE	SE	SE	SE
	3.2	Tyre size, front		315/70-15 (300-15)	315/70-15 (300-15)	315/70-15 (300-15)	315/70-15 (300-15)
	3.3	Tyre size, rear		250/70-15 (250-15)	250/70-15 (250-15)	250/70-15 (250-15)	250/70-15 (250-15)
	3.5	Wheels, number, front/rear (x = driven)		2x/2	2x/2	2x/2	2x/2
	3.6	Track width, front	b10 (mm)	1190	1190	1190	1190
	3.7	Track width, rear	b11 (mm)	1123	1123	1123	1123
Dimensions	4.1	Mast/fork carriage tilt, forward/backward	α/β (°)	5.0/8.0	5.0/8.0	5.0/8.0	5.0/8.0
	4.2	Height of mast when retracted	h1 (mm)	2524	2524	2523	2523
	4.3	Free lift	h2 (mm)	150	150	150	150
	4.4	Lift	h3 (mm)	3100	3100	3100	3100
	4.5	Height of mast when extended	h4 (mm)	4124	4124	4123	4023
	4.7	Height above overhead guard (cabin)	h6 (mm)	2495	2495	2495	2495
	4.8	Seat height relative to SIP/stand height	h7 (mm)	1376	1376	1376	1376
	4.12	Clutch height	h10 (mm)	715	715	714	714
	4.19	Overall length	l1 (mm)	4363	4373	4373	4173
	4.20	Length including fork backs	l2 (mm)	3163	3173	3173	3173
	4.21	Overall width	b1/b2 (mm)	1448	1448	1448	1448
	4.22	Prong dimensions DIN ISO 2331	s/e/l (mm)	50 × 120 × 1200	60 × 130 × 1200	60 × 130 × 1200	60 × 130 × 1000
	4.23	Fork carriage to ISO 2328, class/type A, B		3A	3A	3A	3A
	4.24	Fork carriage width	b3 (mm)	1350	1350	1350	1350
	4.31	Ground clearance under mast	m1 (mm)	205	205	205	205
	4.32	Ground clearance, centre of wheelbase	m2 (mm)	243	243	243	243
	4.34.1	Working aisle width with palette 1000 x 1200 crossways	Ast (mm)	4561 ²⁾	4571 ²⁾	4571 ²⁾	4571 ²⁾
	4.34.2	Working aisle width with palette 800 x 1200 lengthways	Ast (mm)	4761 ²⁾	4771 ²⁾	4771 ²⁾	4771 ²⁾
	4.35	Turning radius	Wa (mm)	2836	2836	2836	2836
	4.36	Smallest pivoting distance	b13 (mm)	842	842	842	842
Performance	5.1	Travel speed, with/without load	km/h	22/22	22/22	22/22	22/22
	5.2	Lifting speed, with/without load	m/s	0.59/0.6	0.56/0.6	0.52/0.6	0.46/0.53
	5.3	Lowering speed, with/without load	m/s	0.55/0.55	0.55/0.55	0.55/0.55	0.55/0.55
	5.5	Tractive force, with/without load	N	8500/8500	8500/8500	8500/8500	8500/8500
	5.6	Maximum tractive force, with/without load	N	22,000/22,000	22,000/22,000	22,000/22,000	22,000/22,000
	5.7	Gradeability, with/without load	%	22.0/32.0; (22.0/36.0) ³⁾	21.0/32.0; (21.0/36.0) ³⁾	19.0/31.0; (19.0/34.0) ³⁾	19.0/30.0; (19.0/34.0) ³⁾
	5.8	Max. gradeability, with/without load	%	18.0/28.0; (18.0/28.0) ³⁾	17.0/28.0; (17.0/28.0) ³⁾	15.0/27.0; (15.0/27.0) ³⁾	15.0/27.0; (15.0/27.0) ³⁾
	5.9	Acceleration time, with/without load	s	5.3/4.6	5.4/4.6	5.5/4.7	5.6/4.7
Drive	5.10	Service brake		hydr./mech.	hydr./mech.	hydr./mech.	hydr./mech.
	6.1	Drive motor, output with S2 60 min	kW	2x 15	2x 15	2x 15	2x 15
	6.2	Lift motor rating at S3 15%	kW	28	28	28	28
	6.3	Battery compliant with DIN 43531/35/36 A, B, C, no		Li-ION	Li-ION	Li-ION	Li-ION
	6.4	Battery voltage/rated capacity (5 h)	(V)/(Ah) o. kWh	90/1440	90/1440	90/1440	90/1440
	6.4.a	Battery energy content	kWh	126.8	126.8	126.8	126.8
	6.5	Battery weight (±5%)	kg	1458	1458	1458	1458
	6.6	CO2 equivalent compliant with EN 16796	kWh/h	8.3	8.8	9.3	9.8
	6.6.1	CO2 equivalent compliant with EN 16796	kg/h	4.49	4.76	5.03	5.3
	Others	8.1	Type of drive unit		Elect. stepped/stepless	Elect. stepped/stepless	Elect. stepped/stepless
10.1		Working pressure for accessory equipment	bar	170	170	170	170
10.2		Oil volume for accessory equipment	l/min	55	55	55	55
10.7		Sound pressure level LpAZ (at the operator's seat)	dB(A)	72	72	72	72
10.8		Towing coupling, design/type, DIN 15170		similar DIN 15170-H	similar DIN 15170-H	similar DIN 15170-H	similar DIN 15170-H
11.2		Stability		1.51	1.49	1.5	1.54

1) incl. battery, lines 6.4/6.5.

2) incl. a = 200 mm safety distance

3) forwards; (backwards)

TECHNICAL DATA (according to VDI 2198)

Characteristics	1.1	Manufacturer (short name)		LINDE MH	LINDE MH	LINDE MH	LINDE MH	
	1.2	Manufacturer's model designation		X50/600	X35/600 Beverage	X40/600 Beverage	X45/600 Beverage	
	1.2a	Series		1254-01	1254-01	1254-01	1254-01	
	1.3	Drive		Battery	Battery	Battery	Battery	
	1.4	Operation		Seated	Seated	Seated	Seated	
	1.5	Load capacity	Q (t)	4.99	3.5	4.0	4.5	
	1.6	Load centre distance	c (mm)	600	600	600	600	
	1.8	Load spacing	x (mm)	535.2	525.2	535.2	535.2	
	1.9	Wheel base	y (mm)	2120	2120	2120	2120	
Weights	2.1	Empty weight	kg	7537 ¹⁾	7343 ¹⁾	7381 ¹⁾	7656 ¹⁾	
	2.2	Axle load with load, front/rear	kg	11,208/1319	9117/1726	9953/1428	10,714/1442	
	2.3	Axle load without load, front/rear	kg	3546/3991 ¹⁾	3759/3584 ¹⁾	3811/3570 ¹⁾	3804/3852 ¹⁾	
Wheels/Tyres	3.1	Tyres solid rubber, SE, pneumatic, polyurethane		SE	SE	SE	SE	
	3.2	Tyre size, front		315/70-15 (300-15)	315/70-15 (300-15)	315/70-15 (300-15)	315/70-15 (300-15)	
	3.3	Tyre size, rear		250/70-15 (250-15)	250/70-15 (250-15)	250/70-15 (250-15)	250/70-15 (250-15)	
	3.5	Wheels, number, front/rear (x = driven)		2x/2	2x/2	2x/2	2x/2	
	3.6	Track width, front	b10 (mm)	1190	1190	1190	1190	
	3.7	Track width, rear	b11 (mm)	1123	1123	1123	1123	
	Dimensions	4.1	Mast/fork carriage tilt, forward/backward	α/β (°)	5.0/8.0	5.0/8.0	5.0/8.0	5.0/8.0
4.2		Height of mast when retracted	h1 (mm)	2523	2974	2974	2973	
4.3		Free lift	h2 (mm)	150	150	150	150	
4.4		Lift	h3 (mm)	2900	3100	3100	3100	
4.5		Height of mast when extended	h4 (mm)	4023	5024	5024	5023	
4.7		Height above overhead guard (cabin)	h6 (mm)	2495	2895	2895	2895	
4.8		Seat height relative to SIP/stand height	h7 (mm)	1376	1776	1776	1776	
4.12		Clutch height	h10 (mm)	714	714	714	714	
4.19		Overall length	l1 (mm)	4373	4363	4373	4373	
4.20		Length including fork backs	l2 (mm)	3173	3163	3173	3173	
4.21		Overall width	b1/b2 (mm)	1448	1448	1448	1448	
4.22		Prong dimensions DIN ISO 2331	s/e/l (mm)	60 × 130 × 1200	50 × 120 × 1200	60 × 130 × 1200	60 × 130 × 1200	
4.23		Fork carriage to ISO 2328, class/type A, B		3A	3A	3A	3A	
4.24		Fork carriage width	b3 (mm)	1350	1350	1350	1350	
4.31		Ground clearance under mast	m1 (mm)	205	205	205	205	
4.32		Ground clearance, centre of wheelbase	m2 (mm)	243	243	243	243	
4.34.1		Working aisle width with palette 1000 x 1200 crossways	Ast (mm)	4571 ²⁾	4561 ²⁾	4571 ²⁾	4571 ²⁾	
4.34.2		Working aisle width with palette 800 x 1200 lengthways	Ast (mm)	4771 ²⁾	4761 ²⁾	4771 ²⁾	4771 ²⁾	
4.35		Turning radius	Wa (mm)	2836	2836	2836	2836	
4.36		Smallest pivoting distance	b13 (mm)	842	842	842	842	
Performance	5.1	Travel speed, with/without load	km/h	22/22	22/22	22/22	22/22	
	5.2	Lifting speed, with/without load	m/s	0.46/0.53	0.59/0.6	0.56/0.6	0.52/0.6	
	5.3	Lowering speed, with/without load	m/s	0.55/0.55	0.55/0.55	0.55/0.55	0.55/0.55	
	5.5	Tractive force, with/without load	N	8500/8500	8500/8500	8500/8500	8500/8500	
	5.6	Maximum tractive force, with/without load	N	22,000/22,000	22,000/22,000	22,000/22,000	22,000/22,000	
	5.7	Gradeability, with/without load	%	18.0/29.0; (18.0/32.0) ³⁾	21.0/31.0; (21.0/33.0) ³⁾	20.0/31.0; (20.0/33.0) ³⁾	19.0/30.0; (19.0/32.0) ³⁾	
	5.8	Max. gradeability, with/without load	%	14.0/25.0; (14.0/25.0) ³⁾	17.0/26.0; (17.0/26.0) ³⁾	16.0/26.0; (16.0/26.0) ³⁾	15.0/25.0; (15.0/25.0) ³⁾	
	5.9	Acceleration time, with/without load	s	5.7/4.7	5.4/4.7	5.5/4.7	5.6/4.8	
Drive	5.10	Service brake		hydr./mech.	hydr./mech.	hydr./mech.	hydr./mech.	
	6.1	Drive motor, output with S2 60 min	kW	2x 15	2x 15	2x 15	2x 15	
	6.2	Lift motor rating at S3 15%	kW	28	28	28	28	
	6.3	Battery compliant with DIN 43531/35/36 A, B, C, no		Li-ION	Li-ION	Li-ION	Li-ION	
	6.4	Battery voltage/rated capacity (5 h)	(V)/(Ah) o. kWh	90/1440	90/1440	90/1440	90/1440	
	6.4.a	Battery energy content	kWh	126.8	126.8	126.8	126.8	
	6.5	Battery weight (±5%)	kg	1458	1458	1458	1458	
	6.6	CO2 equivalent compliant with EN 16796	kWh/h	10	8.4	8.9	9.5	
	6.6.1	CO2 equivalent compliant with EN 16796	kg/h	5.4	4.54	4.81	5.13	
	Others	8.1	Type of drive unit		Elect. stepped/stepless	Elect. stepped/stepless	Elect. stepped/stepless	Elect. stepped/stepless
		10.1	Working pressure for accessory equipment	bar	170	170	170	170
10.2		Oil volume for accessory equipment	l/min	55	55	55	55	
10.7		Sound pressure level LpAZ (at the operator's seat)	dB(A)	72	72	72	72	
10.8		Towing coupling, design/type, DIN 15170		similar DIN 15170-H	similar DIN 15170-H	similar DIN 15170-H	similar DIN 15170-H	
	11.2	Stability		1.52	1.51	1.49	1.5	

1) incl. battery, lines 6.4/6.5.

2) incl. a = 200 mm safety distance

3) forwards; (backwards)

TECHNICAL DATA (according to VDI 2198)

			LINDE MH	LINDE MH	
			X50 / 500 Beverage	X50 / 600 Beverage	
Characteristics	1.1	Manufacturer (short name)	LINDE MH	LINDE MH	
	1.2	Manufacturer's model designation	X50 / 500 Beverage	X50 / 600 Beverage	
	1.2a	Series	1254-01	1254-01	
	1.3	Drive	Battery	Battery	
	1.4	Operation	Seated	Seated	
	1.5	Load capacity	Q (t)	4.99	4.99
	1.6	Load centre distance	c (mm)	500	600
	1.8	Load spacing	x (mm)	535.2	535.2
	1.9	Wheel base	y (mm)	2120	2120
Weights	2.1	Empty weight	kg	7657 ¹⁾	8023 ¹⁾
	2.2	Axle load with load, front/rear	kg	11,219 / 1428	11,489 / 1524
	2.3	Axle load without load, front/rear	kg	3792 / 3865 ¹⁾	3827 / 4196 ¹⁾
Wheels/Tyres	3.1	Tyres solid rubber, SE, pneumatic, polyurethane		SE	SE
	3.2	Tyre size, front		315 / 70-15 (300-15)	315 / 70-15 (300-15)
	3.3	Tyre size, rear		250 / 70-15 (250-15)	250 / 70-15 (250-15)
	3.5	Wheels, number, front / rear (x = driven)		2x / 2	2x / 2
	3.6	Track width, front	b10 (mm)	1190	1190
	3.7	Track width, rear	b11 (mm)	1123	1123
Dimensions	4.1	Mast/fork carriage tilt, forward/backward	α / β (°)	5.0 / 8.0	5.0 / 8.0
	4.2	Height of mast when retracted	h1 (mm)	3073	3073
	4.3	Free lift	h2 (mm)	150	150
	4.4	Lift	h3 (mm)	3100	2900
	4.5	Height of mast when extended	h4 (mm)	5123	5123
	4.7	Height above overhead guard (cabin)	h6 (mm)	2895	2895
	4.8	Seat height relative to SIP/stand height	h7 (mm)	1776	1776
	4.12	Clutch height	h10 (mm)	714	712
	4.19	Overall length	l1 (mm)	4173	4373
	4.20	Length including fork backs	l2 (mm)	3173	3173
	4.21	Overall width	b1 / b2 (mm)	1448	1448
	4.22	Prong dimensions DIN ISO 2331	s / e / l (mm)	60 × 130 × 1000	60 × 130 × 1200
	4.23	Fork carriage to ISO 2328, class / type A, B		3A	3A
	4.24	Fork carriage width	b3 (mm)	1350	1350
	4.31	Ground clearance under mast	m1 (mm)	205	205
	4.32	Ground clearance, centre of wheelbase	m2 (mm)	243	243
	4.34.1	Working aisle width with palette 1000 x 1200 crossways	Ast (mm)	4571 ²⁾	4571 ²⁾
	4.34.2	Working aisle width with palette 800 x 1200 lengthways	Ast (mm)	4771 ²⁾	4771 ²⁾
	4.35	Turning radius	Wa (mm)	2836	2836
	4.36	Smallest pivoting distance	b13 (mm)	842	842
Performance	5.1	Travel speed, with / without load	km/h	22 / 22	22 / 22
	5.2	Lifting speed, with / without load	m/s	0.46 / 0.53	0.46 / 0.53
	5.3	Lowering speed, with / without load	m/s	0.55 / 0.55	0.55 / 0.55
	5.5	Tractive force, with / without load	N	8500 / 8500	8500 / 8500
	5.6	Maximum tractive force, with / without load	N	22,000 / 22,000	22,000 / 22,000
	5.7	Gradeability, with / without load	%	18.0 / 30.0; (18.0 / 32.0) ³⁾	17.0 / 29.0; (17.0 / 30.0) ³⁾
	5.8	Max. gradeability, with / without load	%	14.0 / 25.0; (14.0 / 25.0) ³⁾	14.0 / 24.0; (14.0 / 24.0) ³⁾
	5.9	Acceleration time, with / without load	s	5.7 / 4.8	5.8 / 4.8
Drive	5.10	Service brake		hydr. / mech.	hydr. / mech.
	6.1	Drive motor, output with S2 60 min	kW	2x 15	2x 15
	6.2	Lift motor rating at S3 15%	kW	28	28
	6.3	Battery compliant with DIN 43531 / 35 / 36 A, B, C, no		Li-ION	Li-ION
	6.4	Battery voltage / rated capacity (5 h)	(V) / (Ah) o. kWh	90 / 1440	90 / 1440
	6.4.a	Battery energy content	kWh	126.8	126.8
	6.5	Battery weight (±5%)	kg	1458	1458
	6.6	CO2 equivalent compliant with EN 16796	kWh/h	10	10.2
	6.6.1	CO2 equivalent compliant with EN 16796	kg/h	5.4	5.51
	Others	8.1	Type of drive unit		Elect. stepped / stepless
10.1		Working pressure for accessory equipment	bar	170	170
10.2		Oil volume for accessory equipment	l / min	55	55
10.7		Sound pressure level LpAZ (at the operator's seat)	dB(A)	72	72
10.8		Towing coupling, design / type, DIN 15170		similar DIN 15170-H	similar DIN 15170-H
11.2		Stability		1.54	1.52

1) incl. battery, lines 6.4 / 6.5.

2) incl. a = 200 mm safety distance

3) forwards; (backwards)

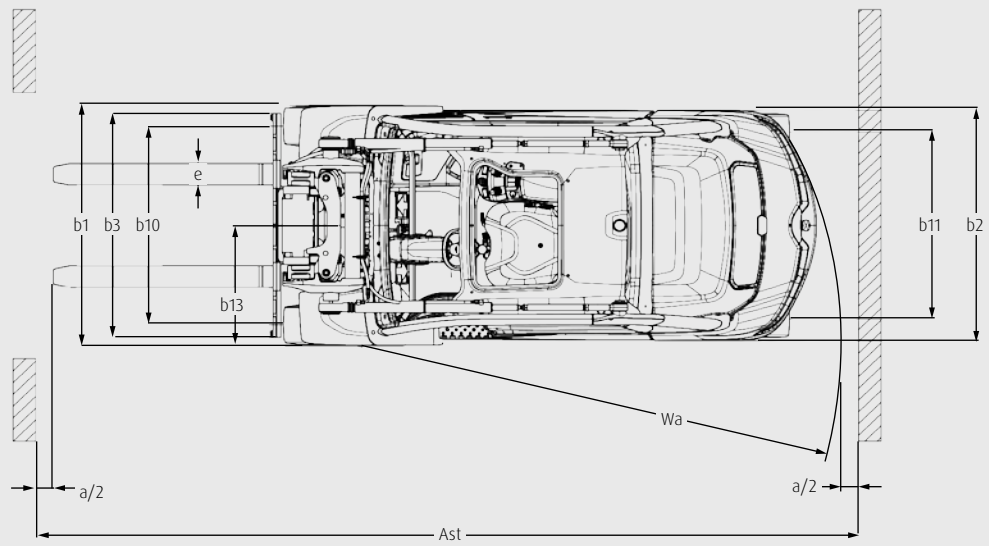
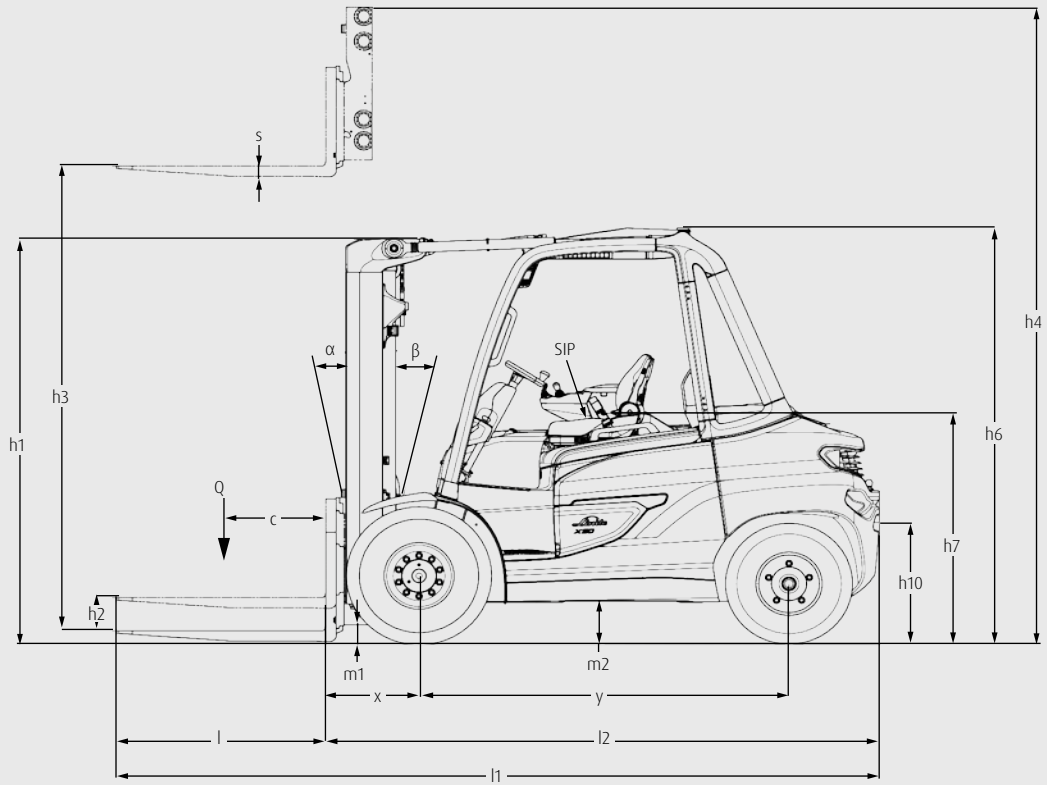

MAST TABLES

STANDARD MAST (in mm)

Series	1534									
Lift	h3: 3200	h3: 3700	h3: 4100	h3: 4400	h3: 5000	h3: 3200	h3: 3700	h3: 4100	h3: 4400	h3: 5000
Height measurements	h1: 2530 h2: 150 h4: 4125	h1: 2780 h2: 150 h4: 4625	h1: 2980 h2: 150 h4: 5025	h1: 3130 h2: 150 h4: 5325	h1: 3430 h2: 150 h4: 5925	h1: 2630 h2: 150 h4: 4225	h1: 2880 h2: 150 h4: 4725	h1: 3080 h2: 150 h4: 5125	h1: 3230 h2: 150 h4: 5425	h1: 3530 h2: 150 h4: 6025
Model										
X35/600	○	○	○	○	○	—	—	—	—	—
X40/600	○	○	○	○	○	—	—	—	—	—
X45/600	○	○	○	○	○	—	—	—	—	—
X35/600 Beverage	—	—	○	○	—	—	—	—	—	—
X40/600 Beverage	—	—	○	○	—	—	—	—	—	—
X45/600 Beverage	—	—	○	○	—	—	—	—	—	—
X50/500	—	—	—	—	—	○	○	○	○	○
X50/600	—	—	—	—	—	○	○	○	○	○
X50/500 Beverage	—	—	—	—	—	—	—	○	○	—
X50/600 Beverage	—	—	—	—	—	—	—	○	○	—

DUPLEX MAST (in mm)

Series	1534					
Lift	h3: 3730		h3: 3130		h3: 3730	
Height measurements	h1: 2730 h4: 4685	h2: 1775	h1: 2530 h4: 4185	h2: 1475	h1: 2830 h4: 4785	h2: 1775
Model						
X35	○	—	—	—	—	—
X40	○	—	—	—	—	—
X45	○	—	—	—	—	—
X50/500	—	—	○	—	○	—
X50/600	—	—	○	—	○	—

TRIPLEX MAST (in mm)

Series	1534											
Lift	h3: 5365		h3: 5865		h3: 6315		h3: 4615		h3: 5565		h3: 6015	
Height measurements	h1: 2680 h2: 1725 h4: 6320	h2:	h1: 2880 h2: 1925 h4: 6820	h2:	h1: 3030 h2: 2075 h4: 7270	h2:	h1: 2530 h2: 1475 h4: 5665	h2:	h1: 2880 h2: 1825 h4: 6615	h2:	h1: 3030 h2: 1975 h4: 7065	h2:
Model												
X35/600	○	—	—	—	○	—	—	—	—	—	—	—
X40/600	○	—	—	—	○	—	—	—	—	—	—	—
X45/600	○	—	—	—	○	—	—	—	—	—	—	—
X35/600 Beverage	—	—	○	—	—	—	—	—	—	—	—	—
X40/600 Beverage	—	—	○	—	—	—	—	—	—	—	—	—
X45/600 Beverage	—	—	○	—	—	—	—	—	—	—	—	—
X50/500	—	—	—	—	—	—	○	—	—	—	—	—
X50/600	—	—	—	—	—	—	○	—	—	—	—	—
X50/500 Beverage	—	—	—	—	—	—	—	○	—	—	○	—
X50/600 Beverage	—	—	—	—	—	—	—	○	—	—	○	—

○ Optional equipment

— Not available

h1: Height of mast, lowered

h2: Free lift

h3: Lift

h4: Height of mast, extended

Figures for other equipment and masts on request

LOAD CAPACITY

X35 / 600

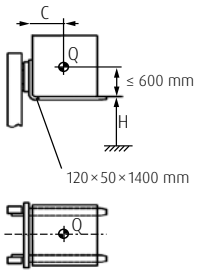

H (mm)	Q (kg)			
7000	2400	2200	2030	1890
6900	2520	2310	2140	1990
6800	2640	2420	2240	2080
6700	2760	2540	2340	2180
6600	2880	2650	2450	2280
6500	3010	2760	2550	2370
6400	3130	2870	2660	2470
6300	3250	2980	2760	2570
6200	3370	3100	2860	2660
≤ 6100	3500	3210	2970	2760
c (mm)	400-600	700	800	900

X40 / 600

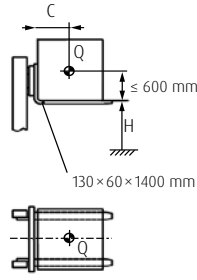

H (mm)	Q (kg)			
7000	2400	2200	2040	1890
6800	2660	2450	2260	2100
6700	2800	2570	2380	2210
6600	2930	2690	2490	2320
6500	3060	2810	2600	2420
6400	3200	2940	2720	2530
6300	3330	3060	2830	2630
6200	3460	3180	2940	2740
6100	3600	3300	3060	2840
6000	3730	3430	3170	2950
5900	3860	3550	3280	3050
≤ 5800	4000	3670	3400	3160
c (mm)	400-600	700	800	900

X45 / 600

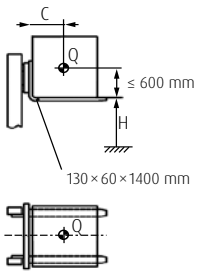

H (mm)	Q (kg)			
7000	2500	2290	2120	1970
6800	2830	2600	2400	2240
6700	3000	2750	2550	2370
6600	3160	2910	2690	2500
6500	3330	3060	2830	2630
6400	3500	3210	2970	2760
6300	3660	3360	3110	2900
6200	3830	3520	3250	3030
6100	4000	3670	3400	3160
6000	4160	3820	3540	3290
5900	4330	3980	3680	3420
≤ 5800	4500	4130	3820	3550
c (mm)	400-600	700	800	900

X50 / 500

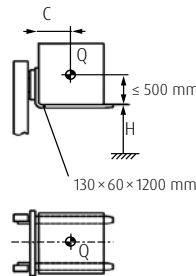

H (mm)	Q (kg)			
7000	2800	2550	2340	2170
6800	3160	2880	2650	2450
6700	3350	3050	2800	2590
6600	3530	3220	2960	2730
6500	3710	3380	3110	2880
6400	3900	3550	3260	3020
6300	4080	3720	3420	3160
6200	4260	3890	3570	3300
6100	4450	4050	3720	3450
6000	4630	4220	3880	3590
5900	4810	4390	4030	3730
≤ 5800	5000	4550	4190	3870
c (mm)	400-500	600	700	800

X50 / 600

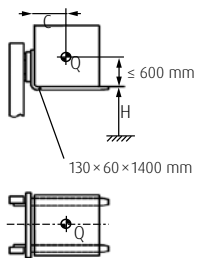

H (mm)	Q (kg)			
7000	2800	2570	2380	2210
6800	3160	2910	2690	2500
6700	3350	3070	2840	2640
6600	3530	3240	3000	2790
6500	3710	3410	3150	2930
6400	3900	3580	3310	3080
6300	4080	3750	3470	3220
6200	4260	3920	3620	3370
6100	4450	4080	3780	3510
6000	4630	4250	3930	3660
5900	4810	4420	4090	3800
≤ 5800	5000	4590	4250	3950
c (mm)	400-600	700	800	900

H = lift height, c = load centre distance, Q = load capacity
Load capacity for standard mast and fork carriage

STANDARD AND OPTIONAL EQUIPMENT

Model/truck equipment		X35 - X50
Operator's workstation	Innovative damping concept helps isolate operator's compartment from harmful vibrations	●
	Ergonomic and safe on/off access to the truck thanks to low non-slip step and handles on the A-pillar and engine cover	●
	Steering wheel with tilt adjustment	●
	Comfort overhead guard for maximum headroom	●
	Operator's seat - quick, easy mechanical weight adjustment	●
	Different operator's seat options: Heated seats, air suspension, active seat suspension, fore/aft suspension	○
	Operator's seat - swivelling seat	○
	3.5" LED colour display including steering angle and tilt angle display	●
	7" LED multifunction colour display integrates additional functions such as cameras and Linde Safety Pilot	○
	Armoured glass roof window	○
	Light metal doors with wide-opening window	○
	DIN A4 terminal board with lighting	○
	Fully integrated heating/air conditioning incl. demisting function	○
Radio, incl. DAB+, MP3 player and Bluetooth hands-free kit	○	
Power unit and braking system	Twin motor front-wheel drive	●
	High performance synchronous reluctance motors (SRM+) for traction and lifting functions	●
	Operating settings - economy, efficiency and performance - for individual performance adjustment	●
	Automatic parking brake	●
Axles and tyres	Super-elastic (SE) tyres	●
	Closed shoulder CS 20 tyres	○
	Pneumatic tyres	○
	Anti-static tyres, non-marking	○
	Dirt deflectors / mud guards, front and rear	○
Mast	High mounted tilt cylinders - including maintenance-free bearings	●
	Optimum visibility due to asymmetric nested mast profiles on standard, duplex and triplex masts	●
	Electronically damped tilt stop	●
Attachments/ forks	Hydraulic accumulator for increased driving comfort, improved load protection and reduced wear and tear	○
	Reinforced Linde forks - easy to adjust and long service life	○
	Integrated roller-guided side shifter provides full nominal load capacity	○
	Integrated fork-positioning carriage "VIEW" for high residual load capacity and optimum visibility	○
	Truck-mounted sweeper option	○
Safety	Linde Curve Assist - automatic reduction of travel speed around corners	●
	Electric seat belt monitoring - visual and audible feedback to ensure seat belt is correctly attached	●
	Linde Load Assist - active intervention in forward tilt and lift speed increases safety at high lift heights	●
	BlueSpot and TruckSpot - visual drive path warning for pedestrians and operators	○
	Load weight display	○
	Linde Safety Pilot - load-dependent driving and lifting speed regulation supports the operator at the limits of truck performance	○
	Linde Safety Guard - audio-visual proximity warning truck-to-truck and between trucks and pedestrians	○
	Speed restriction options - via switch, indoor/outdoor, load- or lift height-dependent	○
	Various truck lighting options: Headlights, full road lighting, working lights, beacons, LED strips, VertiLights	○
Motion detection - registers movement behind the truck and stops reversing	○	
Digitalisation	Online data transmission	●
	WiFi data transmission	○
	Linde connect:desk - local fleet management with different functional modules	○
	Linde connect:cloud - fleet management as a service (hosted version)	○
	Pre-Operation Check - customisable daily inspection log to check the readiness of the truck for operation	○
	Truck Call-App - coordination of transport jobs	○
Operation/ load handling	Double pedal control - smooth acceleration and quick direction changes	●
	Single pedal control with direction selection switch - smooth acceleration and easy direction change	○
	Linde Load Control - central control lever fully integrated into the armrest for precise control of all hydraulic functions	●
	Individual levers fully integrated into armrest for precise control of all hydraulic functions	○

● Standard equipment

○ Optional equipment

CHARACTERISTICS



Panoramic view

Safety

- Narrow mast profiles, A-pillar and roof designed for provide optimum visibility of load and surroundings
- Low centre of gravity and automatic speed reduction in corners reduces the risk of tipping over
- Automatic parking brake ensures safe parking on gradients
- Numerous optional operator assistance systems, lighting and warning systems



Operator's workstation

Ergonomics

- Intuitive, and ergonomic operating concept minimises physical strain on the operator
- Operator's workstation is isolated from the mast and axles by means of rubber bearings, which protects the operator in intensive applications and over uneven ground
- Spacious operator's cab and a range of ergonomic seats for fatigue-free working
- Comprehensive 3.5 inch display optimally positioned for access to all relevant truck information at a glance

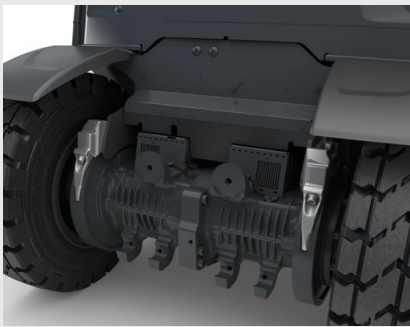

Drive Concept

Handling

- Long wheel base and large diameter tyres give stability when handling loads outdoors and on uneven surfaces
- Twin motor front-wheel drive with high performance synchronous reluctance motors (SRM+) for maximum power and manoeuvrability
- Precise and intuitive control of all driving and lifting movements via twin or single pedal control and Linde Load Control
- Torsion-resistant mast construction and high mounted tilt cylinders result in high residual load capacity and safe, secure load handling



Service access

Service

- High availability due to a robust, modular design as well as numerous wear and maintenance free components
- Low maintenance costs due to long service intervals and easily accessible components
- Remote diagnostics and wireless software updates aid preventive maintenance and reduce the workload for service technicians
- Modular components allow fast diagnosis and quick replacement reducing downtime

Presented by:

Subject to modification in the interest of progress. Illustrations and technical details could include options and are not binding for actual constructions.
All dimensions subject to usual tolerances



Linde Material Handling GmbH
Carl-von-Linde-Platz | 63743 Aschaffenburg | Germany
Phone + 49 6021 99 0 | Fax + 49 6021 99 1570
www.linde-mh.com | info@linde-mh.com

Printed in Germany | DS_X35_X50_1254_en_A_0323