



Electric Counterbalance Truck

E10

Capacity 1.0 t | Series 8917

Maneuverable all-rounder

- Extremely maneuverable electric forklift with small turning radius and compact external dimensions
- Wide range of applications in a wide variety of industries
- Load capacity up to one ton with high tilting stability
- Optimum control concept for precise and fatigue-free operation
- Ergonomic operator's compartment and easy access thanks to low entry step on both sides

TECHNICAL DATA (According to VDI 2198)

Characteristics	1.1	Manufacturer		Linde	Linde
	1.2	Model		E10	E10 Container
	1.2.a	Series		8917	8917
	1.3.	Power Unit		Battery	Battery
	1.4	Operation		Stand-on	Stand-on
	1.5	Load capacity/Load	Q (t)	1.0	1.0
	1.6	Load centre distance	c (mm)	600	600
	1.8	Axle centre to fork face	x (mm)	170 ¹⁾	170 ¹⁾
	1.9	Wheelbase	y (mm)	1129 ¹⁾	1129 ¹⁾
Weights	2.1	Service weight	(kg)	2250 ²⁾	2250 ²⁾
	2.2	Axle load with load, drive side/load side	(kg)	820/2418 ²⁾	820/2418 ²⁾
	2.3	Axle load without load, drive side/load side	(kg)	501/737 ²⁾	501/737 ²⁾
Wheels/Tyres	3.1	Tyres		Tractothan	Tractothan
	3.2	Tyre size, drive side		Ø 254 x 115	Ø 254 x 115
	3.3	Tyre size, load side		2 x Ø 254 x 82	2 x Ø 254 x 82
	3.5	Wheels, number drive side/load side (x = driven wheels)		1x/2	1x/2
	3.7	Track width, load side	b10 (mm)	746	746
Dimensions	4.1	Fork carriage tilt, up/down	a/b (°)	4/2 ³⁾	4/2 ³⁾
	4.2	Height of mast, lowered	h1 (mm)	2190	1990
	4.3	Free lift	h2 (mm)	1630 ⁵⁾	1430 ⁵⁾
	4.4	Lift	h3 (mm)	1660	1460
	4.5	Height of mast, extended	h4 (mm)	2250 ⁶⁾	2050 ⁶⁾
	4.7	Height of overhead guard	h6 (mm)	2190	1995
	4.8	Stand height	h7 (mm)	120	85
	4.9	Height of steering wheel in operating position	h14 (mm)	1052	1052
	4.15	Fork height, lowered	h13 (mm)	40	40
	4.19	Overall length	l1 (mm)	2604 ¹⁾	2604 ¹⁾
	4.20	Length to fork face	l2 (mm)	1454 ¹⁾	1454 ¹⁾
	4.21	Overall width	b1 (mm)	828	828
	4.22	Fork dimensions	s/e/l (mm)	40/80/1150 ⁴⁾	40/80/1150 ⁴⁾
	4.23	Fork carriage to ISO 2328, class/type		2A ⁷⁾	2A ⁷⁾
	4.24	Fork-carriage width	b3 (mm)	650 ⁸⁾	650 ⁸⁾
	4.31	Ground clearance, mast	m1 (mm)	60	60
	4.32	Ground clearance, centre of wheelbase	m2 (mm)	60	60
	4.33	Aisle width with pallet 1000 x 1200 crosswise	Ast (mm)	2862 ¹⁾	2862 ¹⁾
	4.34	Aisle width with pallet 800 x 1200 lengthways	Ast (mm)	2944 ¹⁾	2944 ¹⁾
	4.35	Turning radius	Wa (mm)	1320	1320
4.39	Aisle width without pallet	Ast (mm)	2862 ¹⁾	2862 ¹⁾	
Performance	5.1	Travel speed, with/without load	(km/h)	8/12	8/12
	5.2	Lifting speed, with/without load	(m/s)	0.25/0.42	0.25/0.42
	5.3	Lowering speed, with/without load	(m/s)	0.25/0.22	0.25/0.22
	5.8	Maximum climbing ability, with/without load	(%)	8/15	8/15
	5.9	Acceleration time, with/without load	(s)	-	-
	5.10	Service brake		Electric	Electric
Drive	6.1	Drive motor rating S2 60 min	(kW)	3.0	3.0
	6.2	Lift motor rating at S3 15 %	(kW)	5.7	5.7
	6.4	Battery voltage/rated capacity (5 h)	(V/Ah)	24/300	24/300
	6.5	Battery weight (± 5 %)	(kg)	Min 230	Min 230
Others	8.1	Type of drive control		Electronic	Electronic
	10.7	Noise level at operator's ear	(dB(A))	< 70	< 70

1) + 48 mm with optional fork tilting, side shift or spread unit

2) Alternative lift height and options gives different values

3) With optional tilting fork carriage unit

4) With optional combined fork tilt and side shift and spread unit 40/100/1150 mm

5) - 100 mm with optional fork tilting, side shift or spread unit

6) + 100 mm with optional fork tilting, side shift or spread unit

7) Not used in optional combined fork tilt and side shift and spread unit

8) 800 mm with optional fork tilting, side shift or spread unit

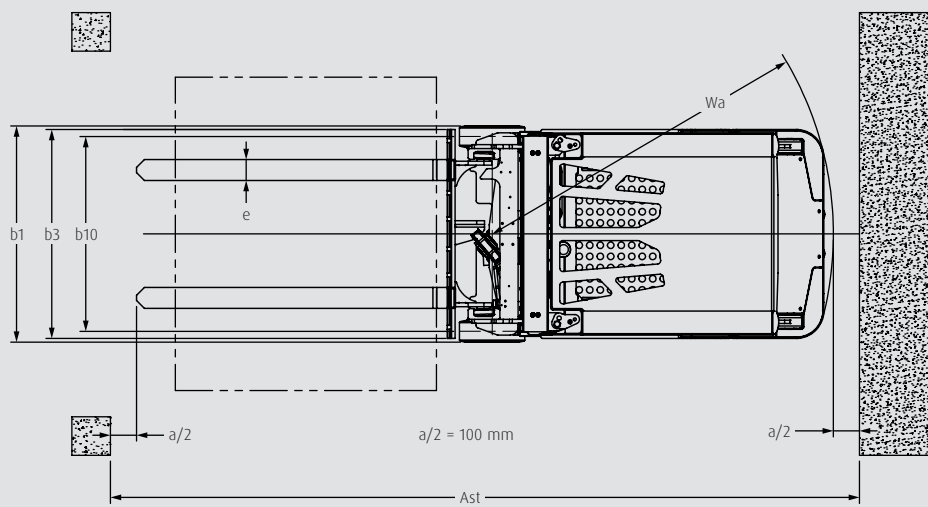
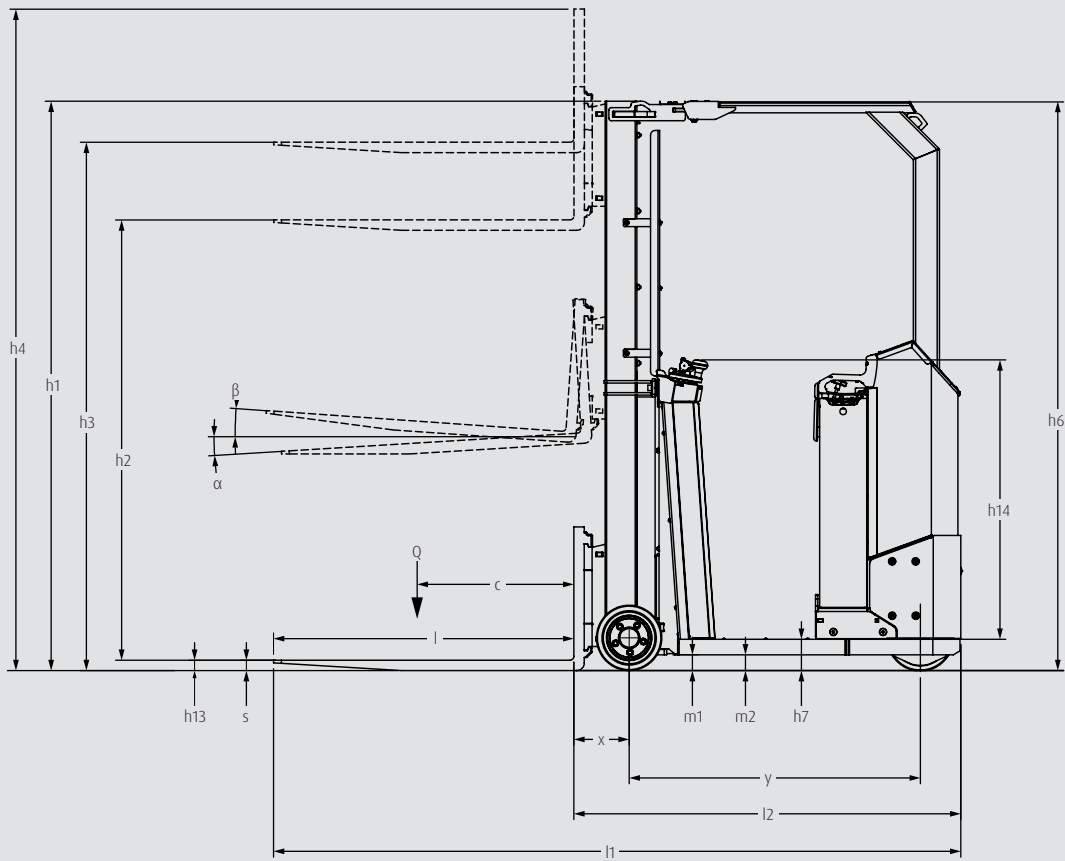

MAST TABLES

STANDARD MAST (in mm)

Lift	h3: 1460	h3: 1660
Height measurements	h1: 1990 h2: 1430 h3: 1460 h4: 2050	h1: 2190 h2: 1630 h3: 1660 h4: 2250
Model		
E10	—	○
E10 Container	○	—

DUPLEX MAST (in mm)

Lift	h3: 2810	h3: 3210	h3: 3610
Height measurements	h1: 1990 h2: 1430 h3: 2810 h4: 3470	h1: 2190 h2: 1630 h3: 3210 h4: 3870	h1: 2390 h2: 1860 h3: 3610 h4: 4270
Model			
E10	—	○	○
E10 Container	○	—	—

TRIPLEX MAST (in mm)

Lift	h3: 4180	h3: 4780	h3: 5380
Height measurements	h1: 1990 h2: 1430 h3: 4180 h4: 4840	h1: 2190 h2: 1630 h3: 4780 h4: 5440	h1: 2390 h2: 1860 h3: 5380 h4: 6040
Model			
E10	—	○	○
E10 Container	○	—	—

○ Optional equipment — Not available

h1: Height of mast, lowered

h2: Free lift

h3: Lift

h4: Height of mast, extended

STANDARD AND OPTIONAL EQUIPMENT

	Model/Equipment	E10	E10 - Container
Safety	Speed reduction system when cornering or lifting forks above free lift	●	●
	Dead mens switch integrated in the floor	●	●
	BlueSpot and TruckSpot - optical warning signal for pedestrians and drivers	○	○
	Flashing beacon beneath overhead guard	○	○
Service	On-board diagnostics system	●	●
	Battery trolley-exchange system	○	○
	Battery carousel-exchange system	○	○
	Battery rollers - Integrated in truck for battery change	○	○
Digitalisation	Linde connect:ac - Access control RFID	○	○
	Linde connect:ac - Access control PIN	○	○
	Linde connect:dt - Crash detection	○	○
Operation / Load Handling	Single command - Including speed adaptive steering, and single lever mast operation	●	●
	Dual command - mirrored accelerating and lever system on the back of the truck	○	○
	360° steering - basic inc. control light	○	○
Electronics	Battery indicator CAN-BUS	●	●
	24 V/60 A HF Charger	○	○
	Lead-Acid Battery - 24 V/300 Ah	○	○
	Lithium-Ion Battery - 25.6 V/200 Ah (LFP)	○	○
Workplace	Ergonomic and safe access to truck due to very low entry step	●	●
	Access on both sides possible	●	●
	Overhead guard against falling objects	●	●
	Combi-Instrument which shows the most important information	●	●
	Vibration decoupled workpace	●	●
	12 V socket	●	●
	Top screen armoured glass - Best protection comes with best visibility	○	○
	Storage compartment - on battery side	○	○
	Din A4 clipboard	○	○
	Foldable side gate - on the left side of the truck	○	○
Internal Panorama mirror mounted with a magnet	○	○	
Mast	Best visibility through narrow mast profiles on standard, duplex, triplex masts	●	●
	5.7 kW maintenance free AC hydraulic pump motor	●	●
	Innovative cylinder system	●	●
Attachment / Forks	Load backrest	○	○
	2° / 4° Tilt attachment	○	○
	Integrated Side Shift	○	○
	Integrated fork positioning	○	○
Axles and Tyres	Tractothan tyres	●	●
	Other Material tyres	○	○
Drive and Brake-System	3 kW AC drive motor which enables travel speeds up to 12 km/h	●	●

● Standard equipment ○ Optional equipment – Not available

CHARACTERISTICS



All-round visibility

Safety

- Optimized design provides outstanding visibility in all directions
- Automatic speed reduction while cornering
- Protective roof against falling loads to protect the driver
- Increased workplace safety through optional warning lights such as Linde BlueSpot™ and Linde TruckSpot™
- Optional flashing warning light for maximum visibility

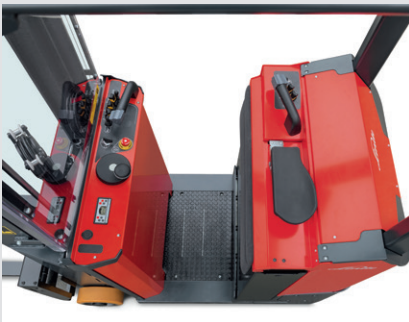

Driver workplace

Ergonomics

- Ergonomic operator's compartment for high operating comfort and fatigue-free work
- Upholstered backrest for comfortable and stable standing
- Operation without changing the hand position reduces strain on the operator
- Low access on both sides of the truck



Lever and steering system

Handling

- Simple and intuitive steering for precise and efficient operation
- Low steering effort due to speed-dependent steering
- Optimum maneuverability thanks to narrow aisle width and small turning radius
- Ideal weight distribution ensures stable driving characteristics
- Optional second dual-command control lever for effortless reverse driving

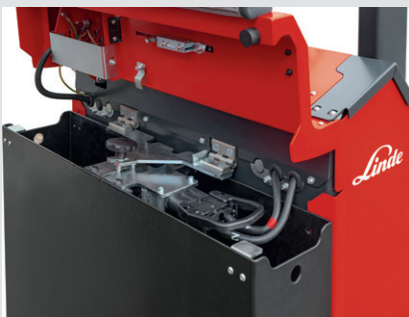

Easy battery access

Service

- Easily accessible vehicle components
- Reduced downtime due to shorter service and maintenance periods
- Easy access to battery behind folding backrest

Subject to modification in the interest of progress. Illustrations and technical details could include options and not binding for actual constructions. All dimensions subject to usual tolerances.